

The Analysis of Coulomb Blockade in Fullerene Single Electron Transistor at Room Temperature

Vahideh KhademHosseini¹, MohammadTaghi Ahmadi^{1,2,4*}, Saeid Afrang^{1,3}, Razali Ismail⁴

¹ Department of Electrical Engineering, Pardis of Urmia University, Urmia, Iran

² Nanotechnology Research Center, Nano electronic Research Group, Physics Department, Urmia University, Urmia, Iran

³ Department of Electrical Engineering, Urmia University, Urmia, Iran

⁴ Faculty of Electrical Engineering, Universiti Teknologi Malaysia, 81310, UTM Johor Bahru, Johor, Malaysia

Received: 2017-05-03

Accepted: 2017-07-10

Published: 2017-08-20

ABSTRACT

The Graphene based single electron transistor (SET) as a coulomb blockade device need to be explored .It is a unique device for high-speed operation in a nano scale regime. A single electron transfers via the coulomb barriers, but its movement may be prevented by coulomb blockade, so its effect is investigated in this research. The conditions of coulomb blockade and its controlling factors such as material, temperature, gate voltage and island length are investigated. At first, the coulomb blockade on fullerene SET as a nano transistor with new material is modeled and compared with experimental data of silicon SET. The comparison study indicates that the coulomb blockade range of fullerene SET is lower than the silicon one. On the other hand, the analysis demonstrates that, temperature and gate voltage play direct associations with zero current SET. In addition, island length and its material effect on coulomb blockade and desired current are achieved by decreasing the coulomb blockade range.

Keywords: Gate voltage, Coulomb blockade, Island length, Fullerene, Single electron transistor
© 2017 Published by Journal of Nanoanalysis.

How to cite this article

KhademHosseini V, Ahmadi MT, Afrang S, Ismail R. The Analysis of Coulomb Blockade in Fullerene Single Electron Transistor at Room Temperature. J. Nanoanalysis., 2017; 4(2): 120-125. DOI: 10.22034/jna.2017.02.004

INTRODUCTION

The Coulomb blockade effect (CB) as an operational principle of single electronic devices has been discussed by C. Gorter for the first time [1]. His research result has expressed that the current was suppressed in low bias voltage because of the coulomb repulsion. This phenomenon has been explained by single electron tunneling and formulated by D. Averin and K. Likharev as the orthodox theory in 1985[2]. After the description

of orthodox theory, the experiments about single electron devices have been increased and led to the building of the first single electron transistor (SET) with metallic island by Dolan and Fulton in 1987[3]. It has worked from 1.1 °K to 4.2 °K that highlights the SET limitation at room temperature operation. This limitation has been improved by using silicon island in SET fabrication 1997[4] that cleared the effect of island material on the SET operation which plays a key role on solving the limitation of SET. Therefore island SET was made of new materials such as graphene as a new carbon

* Corresponding Author Email: mt.ahmadi@urmia.ac.ir

base material in 2010 [5, 6]. On the other hand electrical property of island material, for example carrier mobility and electron transport plays effective roles in SET operation and suppression of coulomb blockade. In this research, fullerene material is selected as an island material due to its ballistic transport and high electron mobility [7, 8]. In the selected structure the SET includes an island between three electrodes named as source, drain and gate. Which contains two tunnel junctions that each tunnel junction is equivalent to a tunnel resistance and a tunnel capacitance as shown in figure 1 [9, 10].

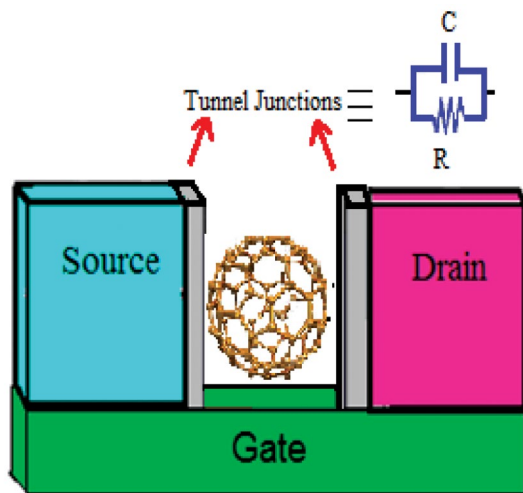

Fig. 1. Single electron transistor.

The electrons tunnel to or out of the island through a tunnel junction. When the first electron passes from a tunnel junction, then the tunnel capacitance is charged. It prevents the second electron tunneling to the island until the first electron leaves the island because the island charge is higher than the bias voltage. This phenomenon can stop the transition of the electron which is called coulomb blockade. Another condition of coulomb blockade will occur if the thermal energy " $k_B T$ " is higher than the charging energy (The essential energy for moving an electron to the island). Moreover tunneling resistance " R_T " less than 25813Ω causes the coulomb blockade effect as well [11-15]. The electron transport is controlled by energy levels, therefore the energy level diagrams of coulomb blockade and a single electron tunneling are shown in figure 2.

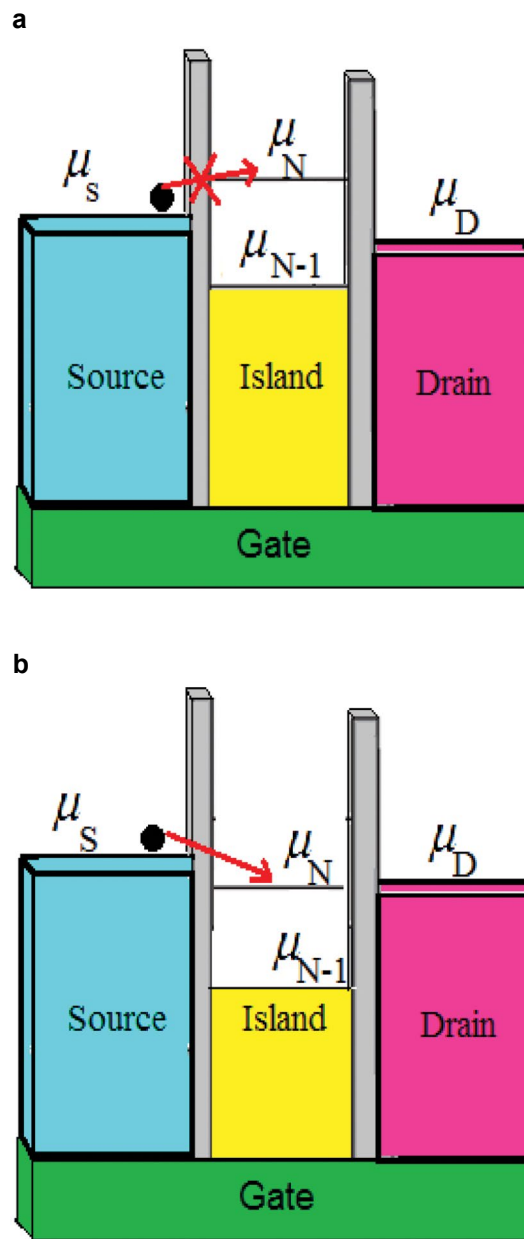

Fig. 2. (a) Coulomb blockade condition happened and the electron doesn't transfer to the island. (b) The electron tunneling occurs and the electron transfers to the island.

In the other words the coulomb blockade condition occurs when the energy level of the island is higher than the source Fermi level and then the electron can't tunnel to island as shown in figure 2-a, but if the energy level of the island is lower than source Fermi level, the electron will move to island and electron tunneling can occur as displayed in figure 2-b. Therefore the current flows by single electron tunneling via the tunnel barriers

in SET. Its current –voltage characteristic is plotted in figure 3. This curve has a coulomb blocked range, and both conductance and current are zero in the coulomb blocked region. The investigation of SET I-V curve indicates that Fermi level of source is equal to the drain Fermi level in the origin as

illustrated in figure 3-a, because any bias voltage isn't applied to SET. Fermi levels of two electrodes are changed by applying voltage as shown in figure 3-b, but electron tunneling to island needs an unoccupied energy level between their Fermi levels as displayed in figure 3-c [16].

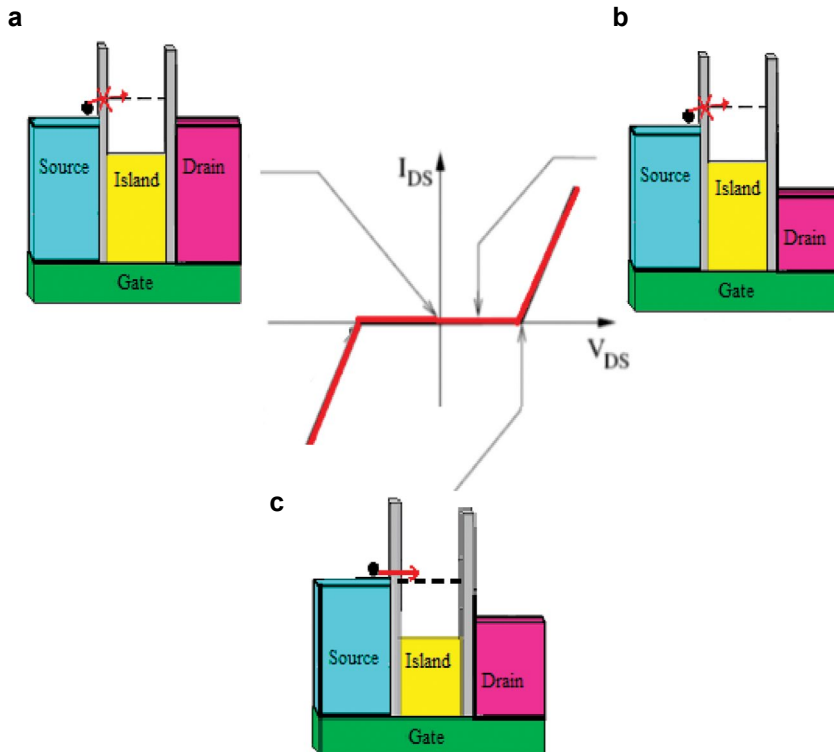

Fig. 3. I-V characteristic of SET. (a) The unequipped energy level is higher than the source Fermi level and coulomb blockade condition occurs. (b) Electrodes Fermi level is changed by applying voltage, but the unequipped energy level is higher than source Fermi level and then coulomb blockade condition occurs. (c) The source Fermi level is equal to an unequipped energy level, therefore an electron transfer to the island.

Modelling

The electron tunneling process has been expressed by a master equation which indicates the change of free energy, background charge (q_0) and the number of electrons in island (N) play important roles in transistor operation. The free energies of two tunnel junctions can be written as

$$\Delta F_1^\pm(n_1, n_2) = \frac{e}{\sum c} \left[\frac{e}{2} \pm (Ne - q_0) \mp (C_G + C_2)V \pm C_G V_G \right] \quad (1)$$

Where ΔF_1^\pm and ΔF_2^\pm are the free energies of left and right tunnel junctions, respectively. Moreover “ C_G ” is gate capacitor, “ C_1 ” and “

C_2 ” are capacitors of either left or right tunnel barriers. The electron can transfer from left to the right direction which is “+” and the right to the left direction which is “-”. Then electron tunneling rate can be calculated as

$$\Gamma_2^\pm(N) = \frac{1}{R_2 e^2} \left[\frac{-\Delta F_2^\pm}{1 - \exp[-\Delta F_2^\pm / K_B T]} \right] \quad (2)$$

By attention to the electron tunneling rate, the current as a function of voltage has been addressed as [17].

$$I(V) = e \sum_{N=-\infty}^{\infty} \rho(N) [\Gamma_1^+(N) - \Gamma_1^-(N)] = e \sum_{N=-\infty}^{\infty} \rho(N) [\Gamma_2^+(N) - \Gamma_2^-(N)] \quad (3)$$

SET works by electron tunneling between different parts of SET such as island and tunnel junctions as marked in figure 4-a. On the other hand, transmitting waves from several regions are expressed with different wave functions by Schrödinger's equations[18]. Furthermore SET energy as a function of channel length is shown in figure 4-b.

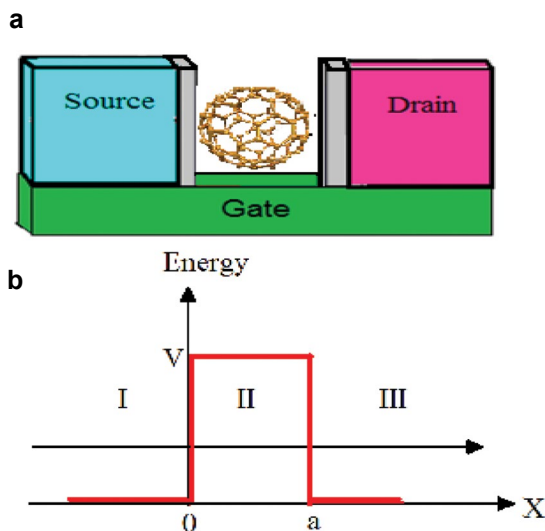

Fig. 4. (a) The SET different parts are electrodes source, drain and gate .Moreover island and two tunnel junctions are shown. (b) Island assumes a channel and SET energy vs. channel length is plotted.

SET has two tunnel junctions which first and the third regions have similar Schrödinger's equations, but island Schrödinger's equation is different from other regions and their equations are expressed respectively as

$$\psi_1(x) = \psi_3 = A_1 e^{ik_1 x} + B_1 e^{-ik_1 x} \text{ Where } k_1 = k_3 = \frac{\sqrt{2m(E)}}{\hbar} \quad (4)$$

$$\psi_2(x) = A_2 e^{k_2 x} + B_2 e^{-k_2 x} \text{ Where } k_2 = \frac{\sqrt{2m(V-E)}}{\hbar} \quad (5)$$

Based on the proposed condition, the transmission coefficient of fullerene SET has been reported by

$$T = \frac{mE(E-E_g)}{mE(E-E_g) + 0.0625(2mE\epsilon a + 2(E-E_g)\hbar^2)^2 \sinh^2\left(\left(\frac{2(E-E_g)}{\epsilon a}\right)^{0.5} L\right)} \quad (6)$$

Where “ E_g ” is energy band gap of fullerene, “ E ” is energy of fullerene, “ m ” is effective mass, “ \hbar ” is plank constant, Eta is $\eta = \frac{E_F - E_g}{K_B T}$, “ T ” is temperature, “ K_B ” is Boltezmann constant , “ L ” is length of island, $a_{c-c} = 1.42A^0$ is carbon-carbon bond length and $t = 2.7ev$ is the nearest neighbor carbon-carbon tight binding overlap energy, also to calculate the drain quantum current based on the Landauer formalism as the well-known current expression can be used and current is modeled as [19, 20].

$$I_d = \int_0^\eta \frac{4c_1 c_2 (K_B T)^2 (x+d) x K_B T dx}{4c_1 c_2 (K_B T)^2 (x+d) x + (c_1 (x+d) + c_2 x)^2 \left((c_2 x d)^2 + \frac{[c_2 x d]^3}{6} \right)^2} e^{x-\eta+1} \quad (7)$$

Where $T(E)$ is transmission coefficient of fullerene SET and $c_1 = \left(\frac{2mK_B T}{\hbar}\right)$, $c_2 = \left(\frac{32mK_B T}{9\hbar(\epsilon a_{c-c})^2}\right)$, $d = \frac{E_g}{K_B T}$, $x = \frac{E - E_g}{K_B T}$ and $\eta = \frac{E_F - E_g}{K_B T}$ also “ m ” is effective mass, “ \hbar ” is plank constant , $a_{c-c} = 1.42A^0$ is carbon-carbon bond length, $t = 2.7ev$ is the nearest neighbor carbon-carbon tight binding overlap energy, “ T ” is temperature, “ K_B ” is Boltezmann constant and “ L ” is island length. To evaluate the proposed model, the current-voltage characteristics of the suggested model and experimental data that are extracted from published data are compared in figure 5 [7].

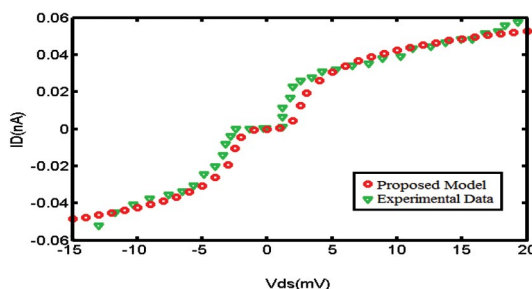

Fig. 5. comparison of current vs. voltage of fullerene SET between proposed model and experimental data that are extracted from reference [7].

The proposed model and experimental data are compared with each other and an acceptable

agreement is reported [7]. Moreover, the effect of island length on coulomb blockade range is investigated as shown in figure 6. The different island lengths are compared with each other, which shows that island length has a direct effect on coulomb blockade range, and more the island length indicates a bigger coulomb blockade region.

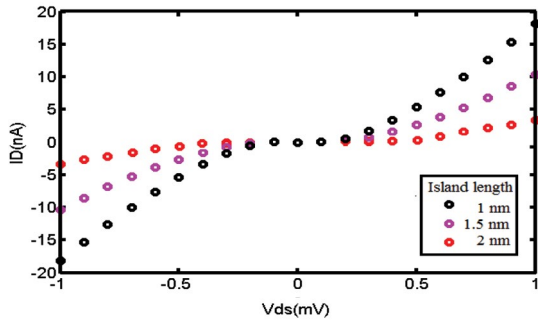

Fig. 6. coulomb blockade ranges based on proposed model are calculated. The fullerene diameters as island lengths are 1nm, 1.5nm and 2nm in SET.

Furthermore, the gate voltage has a notable effect on the coulomb blockade region as shown in figure 7. In attention to the curves of figure 7, it is clear that increasing the applied gate voltage leads to an incremental effect on coulomb blockade range, so this parameter can control the zero current region.

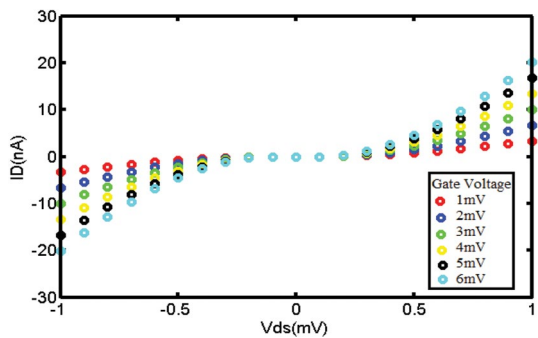

Fig. 7. Coulomb blockade ranges based on proposed model are calculated for different applied gate voltages. The applied gate voltages are 1mV, 2nm, 3mv, 4mv, 5mv and 6mv in fullerene SET.

Based on the presented model, the temperature as an important factor in the SET operation mechanism is explored as shown in figure 8. The result of the temperature up to the room temperature expresses that coulomb

blockade range decreases with increasing the temperature.

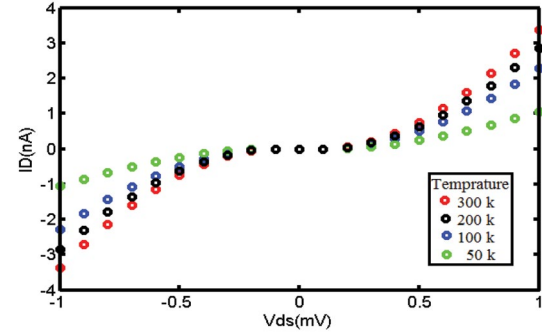

Fig. 8. Coulomb blockade ranges based on proposed model are calculated for different temperatures. The temperatures are 50k, 100k, 200k and 300k in fullerene SET.

Therefore it is confirmed that fullerene SET at room temperature has a lower coulomb blockade range than silicon SET as shown in figure 9 which indicates the higher operating speed and better performance.

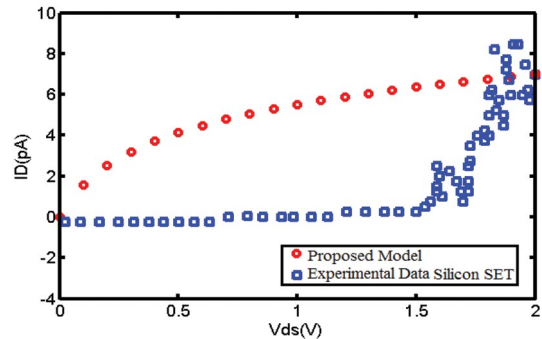

Fig. 9. The comparison current vs. drain voltage of two SETs at room temperature. The red points show the current of the fullerene SET at room temperature. The blue points show the current of silicon SET at room temperature and experimental data are extracted from reference [21].

Maybe it is not the cause to compare the I-V characteristic of fullerene SET by silicon one however to get some senses about its importance, the analysis of I-V characteristic is carried out as shown in figure 9. It is demonstrated that the coulomb blockade range is observed in silicon SET between the drain biases from 0 V to 0.7 V [21] and there is a millivolt of coulomb blockade range in fullerene SET. This analysis again highlights that fullerene SET has lower coulomb blockade

range than the conventional silicon family. Therefore fullerene SET with better operational performance as a replacement of silicon needs to be explored.

CONCLUSION

Single electron transistor (SET) based on graphene as a nano scale transistor, operates by coulomb blockade effect, that cuts transferring of single electron between coulomb barriers, which causes zero current in SET I-V characteristic. In the presented work coulomb blockade current on fullerene based SET is modeled and the obtained results are compared with the silicon SET. It is concluded that the coulomb blockade range of fullerene SET is lower than the silicon one. Moreover island length, gate voltage and temperature have direct effects on zero current range of fullerene SET. In other words, coulomb blockade can be controlled by these parameters in fullerene SET as well. Additionally, millivolt of coulomb blockade range in fullerene SET is observed, which supports the silicon SET replacement in future nanotechnology.

ACKNOWLEDGMENT

The authors would like to acknowledge the financial support of the Ministry of Higher Education (MOHE), Malaysia under the Fundamental Research Grant Scheme (FRGS) project no. Q.J 130000 .7823.4F477. Also thanks to the Research Management Center (RMC) of Urmia University ,Universiti Teknologi Malaysia(UTM) and Universiti Tun Hussein Onn Malaysia (UTHM) for providing excellent research management and environment in which to complete this work.

CONFLICT OF INTEREST

There is not any conflict of interest.

REFERENCES

1. C. J. Gorter, *Physical*. 17, 777 (1951).
2. D. Averin and K. Likharev "Mesoscopic phenomena in solids", 1st ed. B.L. Altshuler, P.A. Lee, W. Richard Webb, 1991, Vol .30, *North-Holland*, Amesterdam, 173.
3. T. A. Fulton and G. J. Dolan, *Phys. Rev. Lett.* , 59, 109 (1987).
4. L. Zhung, L. Guo and S. Y.Chou, *Appl. Phys. Lett.*, 72, 1205 (1998).
5. AK. Geim and KS .Novoselov, *Nature Mater*, 6, 183, (2007).
6. T. Ihn, J Güttinger, F.Molitor, S.Schnez, E.Schurtenberger, A.Jacobsen, S.Hellmuller, T.Fery, S. Droscher , C. Stampfer and K. Ensslin , *Mater. Today*, 13, 3, (2010).
7. H.Park, J.Park, A.K.L.Lim, E.H.Anderson, A.P.Alivisatos and P.L.McEuen, *Nat.* 407, 57 (2000).
8. A. Hirsch, *Nature Mater.* 9, 868 (2010).
9. VV .Shorokhov,DE. Presnov, SV. Amitonov, YA .Pashkin and V.A. Krupenin, *Nanoscale*, 9, 613, (2017).
10. F. Wang, J. Fang ,Sh. Chang, Sh. Qin, X. Zhang and H. Xu ,*Physic Lett A* ,381, 476 (2017).
11. W.A.Schoonveld, J.Wildeman, D.Fichou, P.A.Bobbert, B.J.van Wees and T.Klapwijk, *Nat.* 404, 977 (2000).
12. J.Park, A.N.Pasupathy, J.I.Goldsmith, C.Chang,Y. Yaish, J.R Petta, M.Rinkoski, J.P.Sethna, H.D. Abruña, P.L.McEuen and D.C.Ralph, *Nat.* 417, 722 (2002).
13. M.Ejrnaes, M.T.Savolainen b, M.J.Manscher and A.Mygind, *Physica C*, 372, 1353 (2002).
14. H. Zheng, M. Asbahi, S. Mukherjee, C. J Mathai, K. Gangopadhyay, J. K W Yang and Sh.Gangopadhyay, *Nanotech.* 26, 35 (2015).
15. F. Willy, Y. Darma, J. Phys.: Conference Series, 739 (2016).
16. J. Weis, "CFN Lectures on Functional Nanostructures" 1st ed. K.Busch, A.K.Powell, , C.Röthig, G.Schön and J. Weissmüller, 2005,Vol. 1,chap. 6, *Springer Berlin Heidelberg*, 87.
17. L.Sheela, N.B.Balamurugan, S.Sudha and J.Jasmine, *JEET*, 9, 1670 (2014).
18. E. Schrödinger,*Physic Rev.*, 28, 1049 (1926).
19. R. Landauer *Philos. Mag.*, 21, 863 (1970).
20. S. Datta, "Electronic Transport in Mesoscopic Systems", 1st ed. H. Ahmed, 1995, *Cambridge University Press*, Cambridge, UK.
21. A.Z.Khan Durrani, "Single-electron Devices and Circuits in Silicon", 1st ed. 2010, Chap. 3, Imperial College Press, London UK, 127.